



Code ✓ Check[®] Building[®] 2nd Edition

BY DOUGLAS HANSEN, REDWOOD KARDON, AND MICHAEL CASEY

Illustrations and Layout: Paddy Morrissey

© 2006 by The Taunton Press, Inc. ISBN 1-56158-595-5

Code Check[®] is a registered trademark of The Taunton Press, Inc., registered in the U.S. Patent and Trademark Office.

Based on Chapters 1 through 11 of the 2006 International Residential Code[®]

For more information on the Building, Electrical, Mechanical and Plumbing codes, valuable resources, and why Benjamin Franklin is featured in the Code Check series, visit: www.codecheck.com

Code Check Building is a condensed guide to the building portions of the 2006 International Residential Code (IRC) for One- & Two-Family Dwellings. Most building jurisdictions around the country have either adopted the IRC or a code that is based upon it. The IRC is prescriptive and simpler to use than the International Building Code (IBC), or the legacy codes that preceded the IBC. For example, the IBC has different occupancy categories for garages and for dwellings, and users must move back and forth between different chapters to find all the rules for the fire-resistive construction to separate the two occupancies. The IRC simply prescribes the covering that must be on the garage side.



In 1735, Benjamin Franklin organized the first volunteer fire department in Philadelphia which still remains the model for U.S. fire departments.

KEY

Each text line ends with an IRC code reference in brackets, ex:

Ceiling height in habitable spaces min 7ft _____ [305.1]

The rule for minimum ceilings heights in habitable spaces is found in section 305.1.

Note: In the IRC, the number is actually R305.1. We have omitted the letter at the beginning to save space and include more information on each line.

A colored code citation followed by a superscript number indicates a change from the 2003 edition of the IRC, ex:

Unrated walls min 5ft to property line _____ [302.1]¹

This rule changed in the 2006 edition. The change is explained as item #1 on the list of significant code changes on the inside back cover.

T1 refers to Code Check Building Table 1, ex:

Determine Seismic Design Category **T1** _____ [301.2.2.1]

F1 refers to Code Check Building Figure 1, ex:

Setbacks and clearances to slopes >1 vert: 3 horiz **F1** _____ [403.1.7]

The word "OR" at the end of the line means that an alternative rule follows.

The word "EXC" at the end of the line means that a code exception follows.

FIG. 1

The Building System

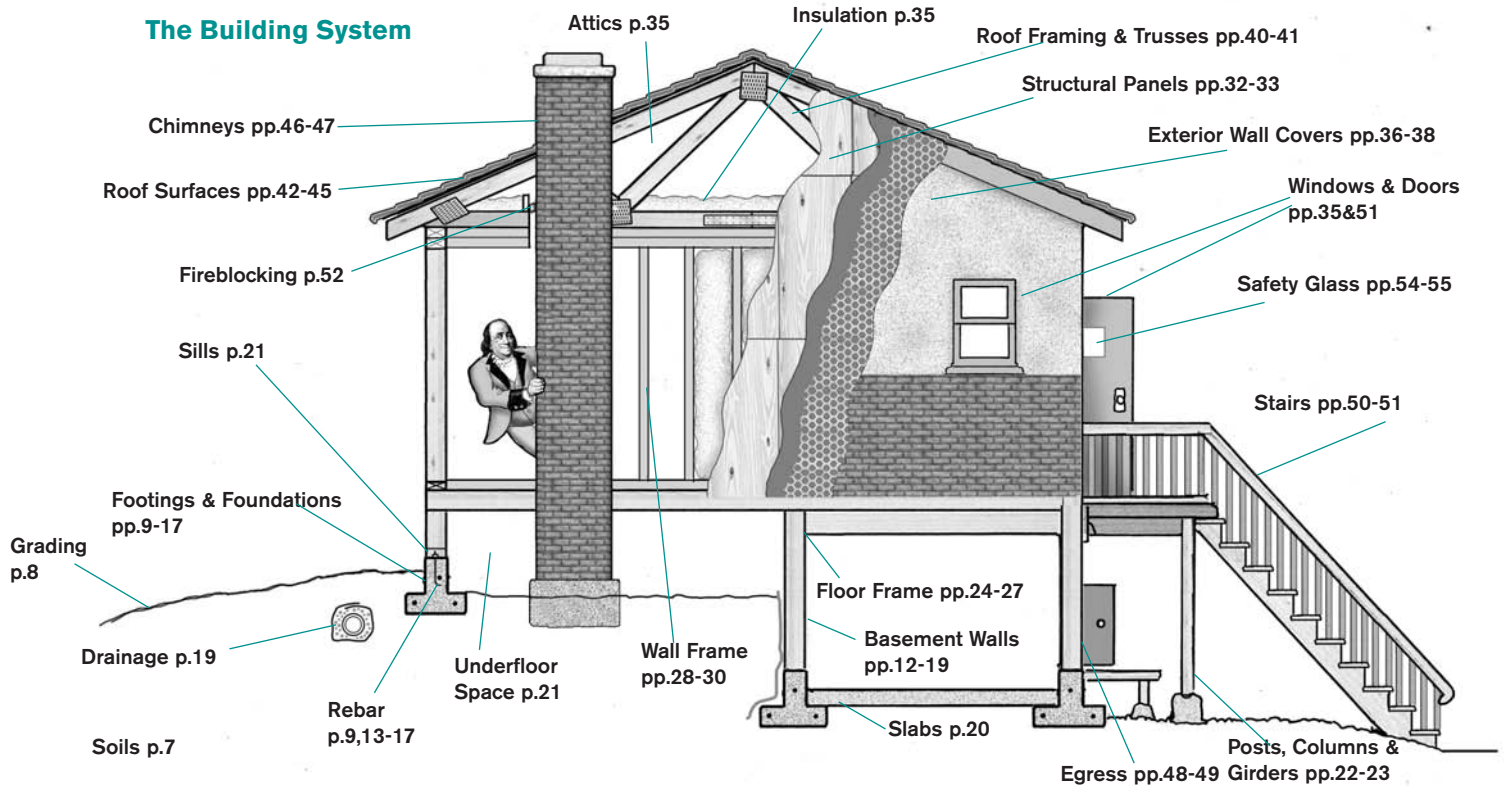

FIG. 3 Buildings Near Slopes >1:3

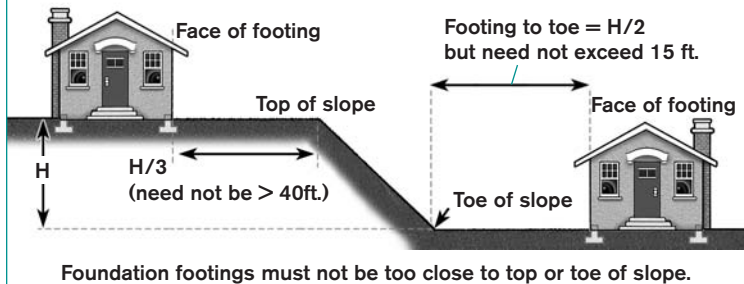
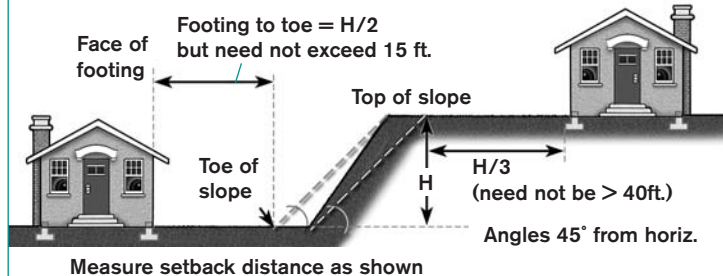

FIG. 4 Buildings Near Slopes >1:1



SITE GRADING

Site grading must establish a foundation height that will allow positive drainage slope away from the building, while at the same time not creating a situation where the foundation is placed on fill, other than engineered and compacted fill. The basic rule is to have positive slope for 10 feet in all directions from the building, with surface drainage directed to a storm sewer or equivalent. A new rule in the 2006 IRC allows an exception for situations where the building is close to the property line or there are physical barriers that prevent positive slope for 10 feet. In those cases, the grading can have a 5% slope to a swale.

Slope/Grade

- Surface graded away from foundation min 6in/10ft **F5** EXC _____ [401.3]
5% slope to swale OK when barrier prevents 6in/10ft _____ [401.3X]⁵
- Swale min slope 2% when closer than 10ft to bldg _____ [401.3X]
- Setbacks & clearances to slopes >1 vert: 3 horiz **F3** _____ [403.1.7]
- Setbacks & clearances to slopes >1 vert: 1 horiz **F4** _____ [403.1.7]
- Alternate setbacks permitted w/ approval of BO _____ [403.1.7.4]
- Graded site—top of foundation min 12in+2% above street drain **F5**[403.1.7.3]

FIG. 5

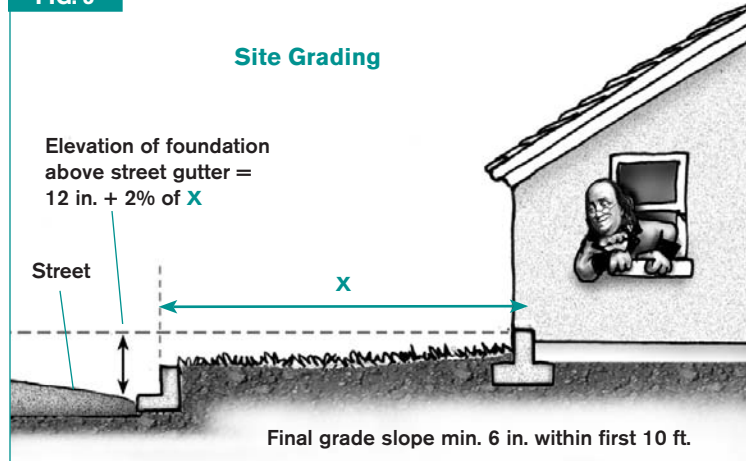

FOOTINGS

The foundation footing must be capable of supporting all loads transmitted to it, including the dead loads, live loads, and environmental loads. Footings must be supported on previously undisturbed material or on engineered fill; care must be taken in grading a site to ensure that footings are not cast on unconsolidated soil. The footing is typically cast monolithically with the foundation on houses with crawlspaces and “inverted T” foundations, or slabs-on-grade.

Footings

- Depth min 12in into undisturbed native soil or engineered fill **F6** [403.1.4, 403.1]
- Must extend below frost line or be frost-protected _____ [403.1.4.1]
- Width per **T5** _____ [403.1.1]
- Min. thickness 6in _____ [403.1.1]
- Min projection past foundation 2in each side, max projection ≤ footing thickness **F6** _____ [403.1.1]
- SDC D₀, D₁ & D₂ monolithic slab interior footings below bearing or braced walls min 12in deep from top of slab _____ [403.1.4.2]⁶
- Foundations & slabs on expansive soil req design to prevent uplift _ [403.1.8]
- Top surface of all footings level _____ [403.1.5]
- Bottom surface of footings max slope 1:10 (create steps where necessary) [403.1.5]

TABLE 4

REINFORCING STEEL COVER^A

Foundation Surface	Min. Cover ≤ # 5 bars	Min. Cover ≥ # 6 bars
Concrete cast against & permanently exposed to earth	3in.	3in.
Concrete exposed to earth or weather	1in.	2in.
Not exposed to weather, e.g. top of indoor slab	¾in.	¾in. up to # 11 bars

A. The cover in this table is recommended by ACI 318, Building Code Requirements for Structural Concrete. This document is the industry standard for proper practices. These #'s are not specifically a part of the IRC.

TABLE 5

MIN. WIDTH OF CONCRETE OR MASONRY FOOTINGS (IN INCHES) [T403.1]

Construction Type	# of Stories	Load Bearing Value of Soil ^A (psf)			
		1,500	2,000	3,000	≥4,000
Conventional light-frame construction	1	12	12	12	12
	2	15	12	12	12
	3	23	17	12	12
4 in. brick veneer over frame or 8 in. hollow-concrete masonry	1	12	12	12	12
	2	21	16	12	12
	3	32	24	16	12
8 in. solid or fully grouted masonry	1	16	12	12	12
	2	29	21	14	12
	3	42	32	21	16

A. See **T3** for vertical load-bearing values of different soil types.

FORMS

Foundation forms contain concrete while it is still in its fluid state & provide protection for reinforcing steel & other elements that are to be permanently embedded. Forms must not be removed until the concrete is sufficiently cured, & all traces of wood forms must be removed to prevent any potential wood-destroying organism from entering the building.

Forms

- Size per tables **T7,9,10** _____ [404.1.1,2]
- Pipe penetrations must be sleeved _____ [2603.5]
- Excavation free of debris & roots _____ [408.5, 506.2]
- Wood beam connections 1/2in air space on 3 sides **F7** _____ [319.1]
- Foundation wall to extend min 6in above finish grade EXC _____ [404.1.6]
4in OK if masonry veneer to be used _____ [404.1.6]

FIG. 6

T Foundation with Box Forms

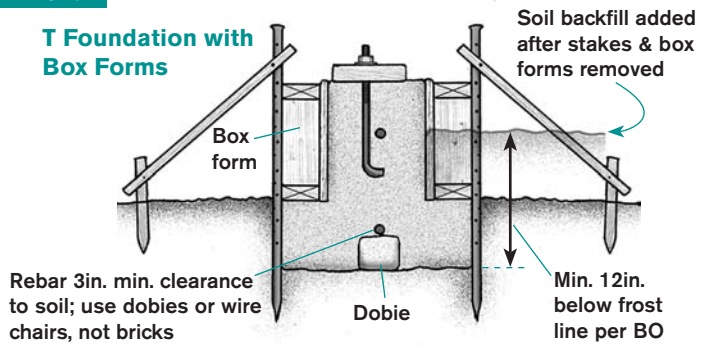
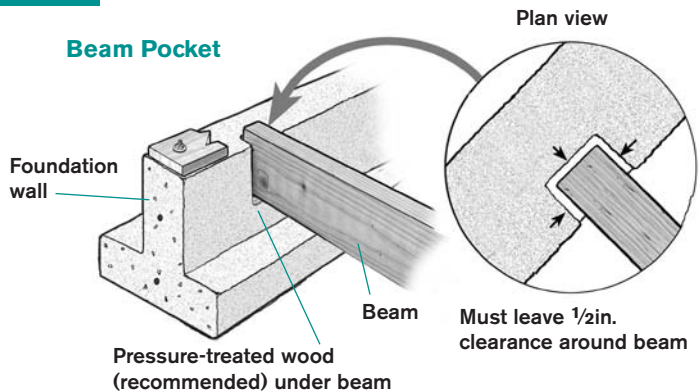

FIG. 7

Beam Pocket



CONCRETE

Concrete must have sufficient strength for the application and environment. Hi-strength concrete (>2,500 psf) might require special inspections (table 2). In general, the more northern the latitude, the more severe the weathering potential. ACI 318 defines the testing standards for concrete.

Mixing and Strength

Min compressive strength per **T6** _____ [402.2]

Materials and testing to conform to ACI 318 _____ [402.2]

TABLE 6	MIN. COMPRESSIVE STRENGTH OF CONCRETE (AT 28 DAYS) IN PSI [T402.2]			
	Type or Location of Concrete Construction	Weathering Potential		
		Negligible	Moderate	Severe
	Basement walls, foundations & other concrete not exposed to the weather	2,500	2,500	2,500 ^A
	Basement slabs & interior slabs on grade, except garage floor slabs	2,500	2,500	2,500 ^A
	Basement & foundation walls, exterior walls & other vertical concrete exposed to weather	2,500	3,000 ^b	3,000 ^B
	Porches, carport slabs & steps exposed to the weather, & garage floor slabs	2,500	3,000 ^{B,C}	3,500 ^{B,C}

A. Must be air-entrained if exposed to freeze-thaw during construction.
 B. Air-entrainment req'd. Air content between 5 & 7 percent by volume of concrete.
 C. Garage floor slab air-entrainment may be reduced to 3 percent if strength increased to 4,000 psi.



Code Check[®] Plumbing Third Edition

BY DOUGLAS HANSEN, REDWOOD KARDON, AND MICHAEL CASEY

Illustrations and Layout: Paddy Morrissey

© 2007 by The Taunton Press, Inc. ISBN 1-56158-595-5

Code Check[®] is a registered trademark of The Taunton Press, Inc., registered in the U.S. Patent and Trademark Office.

For more information on the building, electrical and mechanical codes, valuable resources, and why Benjamin Franklin is featured in the Code Check series, visit www.codecheck.com

Code Check Plumbing is based on the 2006 International Residential Code and the 2006 Uniform Plumbing Code—the two most widely used residential plumbing codes. For areas that using older code editions, this book has a feature that highlights recent code changes and summarizes them on pp. 120–121. Before beginning a building project, we recommend checking with your local building department to determine which codes are used in your area.

KEY TO USING CODE CHECK PLUMBING

Code references are followed by two bracketed numbers, ex:

Code reference **T1,F1** _____ [123.4] {123.4}

Code numbers on left, in brackets, ex: [123.4], refer to IRC codes.

Code numbers on right, in braces, ex: {123.4}, refer to UPC codes.

T1 refers to Table 1. **F1** refers to Figure 1.

[manu] = Typically required by manufacturer's installation instructions.

[2407.15X] = An X after a code number refers to an exception in code.

EXC = When placed at end of text line signals an exception in following line.

OR = When placed at end of text line signals an alternative in following line.

n/a = not addressed by the IRC. {n/a} = not addressed by the UPC.

[Ø] = Prohibited by the IRC. {Ø} = Prohibited by the UPC.

[brackets] or {braces} in a text line restrict that text to the [IRC] or {UPC} codes.

Codes ending in numbers separated by commas refer to multiple code sections, ex: [1802.1,2407.3] = IRC sections 1802.1 and 2407.3. A colored code citation with a superscript number indicates a change in the code.

ex: [3005.2.9]⁹ refers to a code change in the IRC, listed as #9 in the code change summary on p. 120.

Example (from p. 68)

Sleeve pipes through footings, fndns

{& concrete floors}{does not apply to bored holes} ____ [2603.5] {313.10.1}¹

The IRC and UPC require a sleeve around any pipe passing through footings and foundations. In addition, the UPC requires a sleeve for pipes passing through concrete floors. The braces indicate that the rule for floors is only in the UPC, not the IRC. The different color for the UPC citation tells us it is a code change, and the superscript 1 tells us the change is #1 in the list on the p.120.

Example (from p. 86)

Vent connection at interconnection of fixt drains OR ____ [3107.2] {905.6}

[Downstream of interconnection] **F23,34** _____ [3107.2] {Ø}

In the IRC, a vent may connect where fixture drains are joined or downstream from where they connect. In the UPC, they must connect where they are joined. These practices are shown in Figures 23 and 34.

ABBREVIATIONS

AAV(s) = air admittance valve(s)
ABS = acrylonitrile-butadiene-styrene drain (black plastic drain pipe)
ACH = air changes per hour
AHJ = authority having jurisdiction (agent of building official)
appl(s) = appliance(s)
AWG = American wire gauge
B (vent) = double-walled gas appliance flue
BA = bathroom
bldg(s) = building(s)
BO = building official
BR = bedroom
BT = bathtub
Btu(s) = British thermal unit(s)
CI = cast iron
CO = cleanout
CO₂ = carbon dioxide
CPVC = chlorinated PVC
CSST = corrugated stainless-steel tubing (for gas)
cu = cubic
Cu = copper
CW = clothes washer
CWV = combination waste & vent
DFU = drainage fixture unit
dia = diameter
DWV = drain, waste, & vent
eqpmt = equipment
ex. = example

exc = except
ext = exterior
Fe = iron or steel pipe
fixt(s) = fixture(s)
FLR = flood level rim
fndn(s) = foundation(s)
ft = foot, feet
FVIR = flammable vapor ignition resistant
gal = gallons
GPM = gallons per minute
horiz = horizontal
in = inch(es)
k = 1,000
KS = kitchen sink
lav(s) = bathroom lavatory sink(s)
L&L = listed & labeled
LT = laundry tub
manu(s) = manufacturer(s)
max = maximum
min = minimum
O.C. = on center
PB = polybutylene
PE = polyethylene
PEX = cross-linked polyethylene water tubing
PEX-AL-PEX = PEX-aluminum-PEX tubing
PMI = according to manufacturer's instructions
PRV = pressure-relief valve

psi = pounds per square inch
psig = pounds per square inch gauge
PVC = polyvinyl chloride
req(s) = require or requirement, requirements
req's, req'd = requires, required
SDC = seismic design category
sq = square

temp = temperature
TJI* = manufactured I-joists
TPRV = temperature & pressure relief valve
vert = vertical
w/, w/o = with, without
WC(s) = water closet(s), toilet[s]
WH(s) = water heater(s)

CODE CHECK PLUMBING CODES

Code Check Plumbing 3rd Edition references these two codes:

2006 IRC (*International Residential Code*—published by ICC—the International Code Council) and

2006 UPC (*Uniform Plumbing Code*—published by IAPMO—the International Association of Plumbing and Mechanical Officials)

If your area is using an earlier edition of one of these codes, take special note of the highlighted code changes and use the list on pp. 120–121 to aid in proper application of the appropriate rules.

In 1752, Benjamin Franklin brought the first bathtub to the United States.

After designing a more comfortable model, he took it with him on his many travels to Europe.



FIG. 1

The Plumbing System

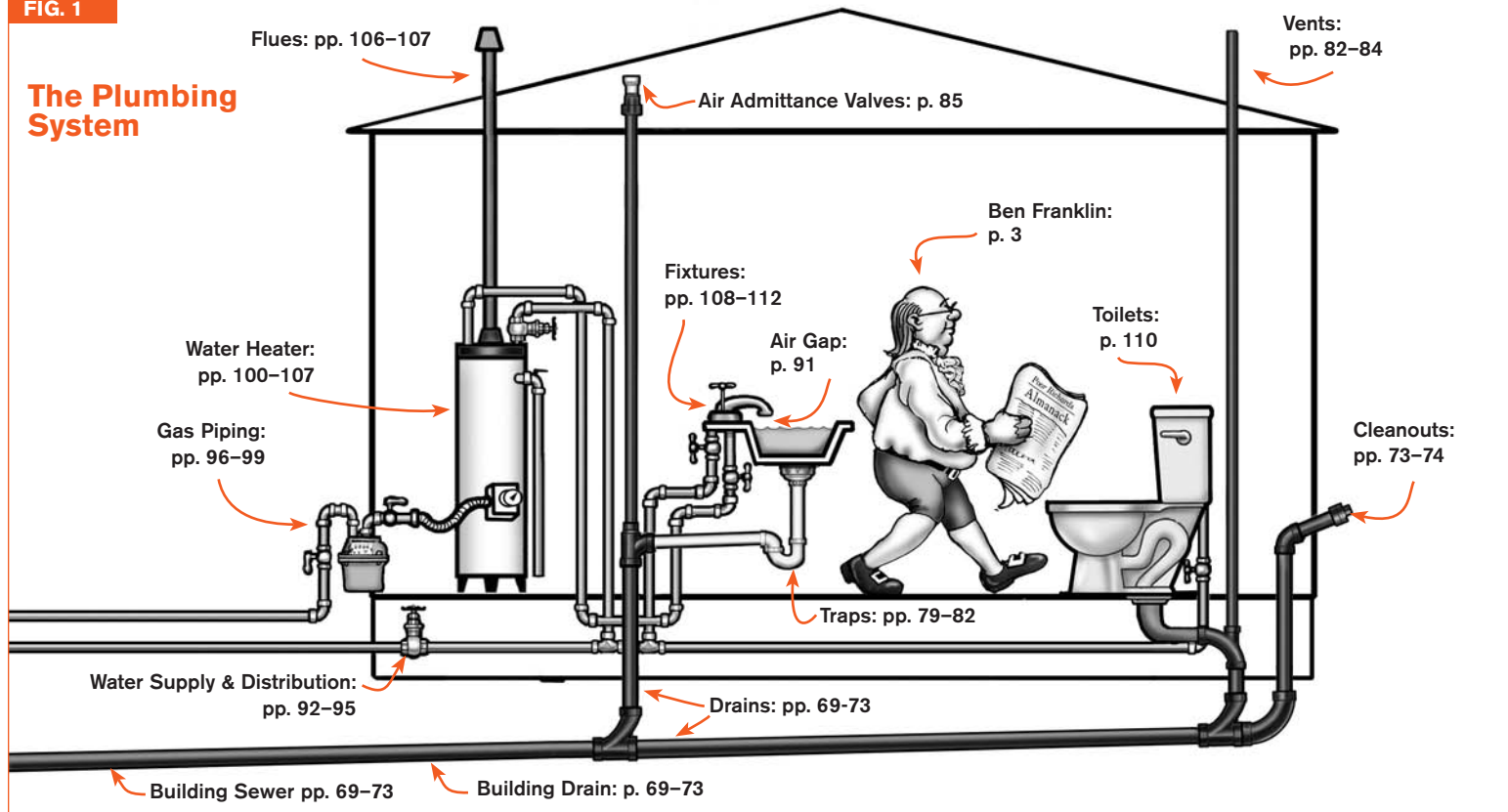

FIG. 7

Closet Bend Reductions

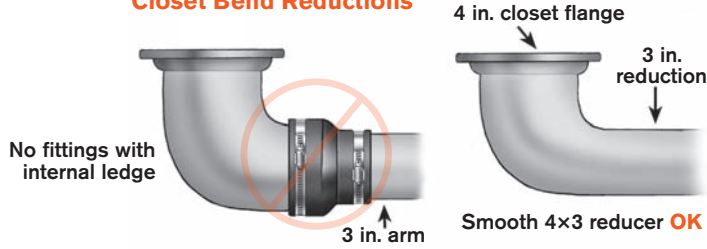
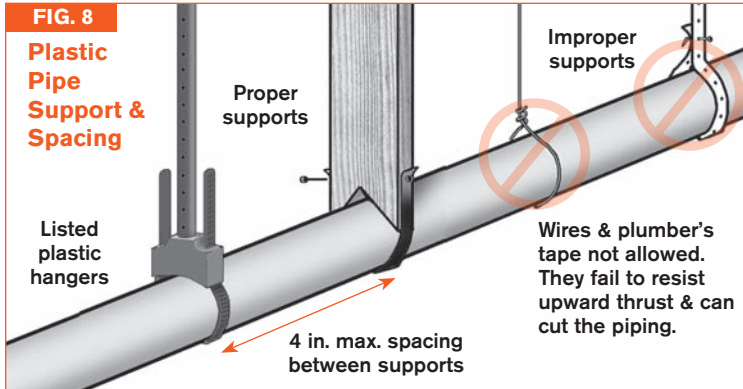

FIG. 8

Plastic Pipe Support & Spacing



- A. The IRC recognizes a BA group designation that includes the WC, lav, bidet, and BT or shower located together on the same floor. The designation is important because it allows for horiz. wet venting. For bath groups with 1.6 gal./flush toilets: subtract 1 fixt. unit.
- B. For these fixts., the UPC req's a 2 in. drain after the trap arm. The IRC allows the same size drain as the trap.
- C. Applies only to showers w/ a total flow rate through showerheads and bodysprays totaling 5.7 GPM. For showers >5.7 GPM the min. trap size is 2 in.⁴

TABLE 3

DFU LOAD & TRAP SIZE

[3004.1] & [3201.7] [T7-3]

Fixt.	Fixt. Units		Min. Trap Size (in.)	
	IRC	UPC	IRC	UPC
Bar sink	1	1	1 1/2	1 1/2
Bath/shower	2	2	1 1/2	1 1/2
Full BA group ^A	6	n/a	n/a	n/a
Bidet	1	1	1 1/4	1 1/4
CW standpipe	2	3	2	2
LT	2	2	1 1/2	1 1/2
Laundry group	3	n/a	n/a	n/a
KS	2	2	1 1/2	1 1/2 ^B
DW	2	2	1 1/2	1 1/2 ^B
KS w/ DW	2	2	1 1/2	1 1/2 ^B
KS w/ disposer	2	2	1 1/2	1 1/2 ^B
Lav.	1	1	1 1/4	1 1/4
Shower Stall	2	2	1 1/2 ^{C a}	2
WC >1.6 gal./flush	4	4	n/a	n/a
WC < 1.6 gal./flush	3	3	n/a	n/a
Floor drain	0	0	2	2

FIG. 10

Application of Fittings

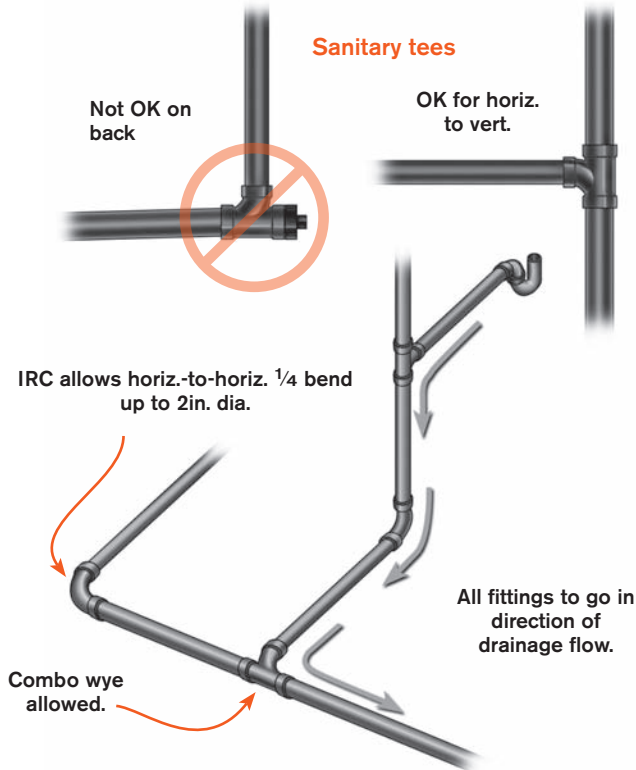

CLEANOUTS

Drain cleanouts at accessible locations provide access for snaking obstructions from a pipe or viewing the pipe interior with a sewer camera.

IRC CO Requirements

IRC

- Same size as drain pipes up to 4in EXC _____ [3005.2.9]⁹
CO in stack can be one size smaller than drain _____ [3005.2.9]¹⁰
- Removable traps OK as CO for drains up to 1 size larger than trap _____ [3005.2.9X1, 10]
- Req'd at base of stack or outside within 3ft of bldg wall **F14** _____ [3005.2.6]
- Req'd near junction of bldg drain & bldg sewer EXC _____ [3005.2.7]
Not req'd if CO on 3in soil stack located within 10ft of bldg sewer [3005.2.7]¹¹
- 2-way CO OK at bldg drain & bldg sewer _____ [3005.2.7]¹²
- Pipes <3in req 12in clearance; ≥3in: req 18in _____ [3005.2.5]
- Req'd each 100ft of straight horiz run _____ [3005.2.2]
- Req'd in horiz drains each change of direction >45° exc only 1 CO req'd per 40ft of run **F12** _____ [3005.2.4]
- CO openings: not OK for new fixts unless new CO installed _ [3005.2.11]

UPC CO Requirements

UPC

- Size per **T7** _____ {707.11}
- Req'd at upper terminal of horiz runs on first floor OR 2-way CO near junction of bldg drain & bldg sewer **F11** _____ {707.4}
- Additional CO req'd horiz runs aggregate >135° **F12** _____ {707.5}
- Not req'd for horiz runs <5ft (exc sinks) _____ {707.4X1}
- Not req'd if slope >4in/ft _____ {707.4X2}
- Takeoff above flow line exc wye branch or end of line _____ {707.6}
- Pipes ≤2in req 12in clearance; >2in req 18in clearance **T7** _____ {707.10}
- Underfloor CO not >20ft from access door _____ {707.10}
- Passageway to underfloor CO min 30in horiz by 18in vert _____ {707.10}

FIG. 35

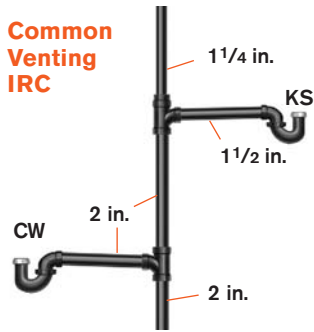

FIG. 37

Common Venting UPC

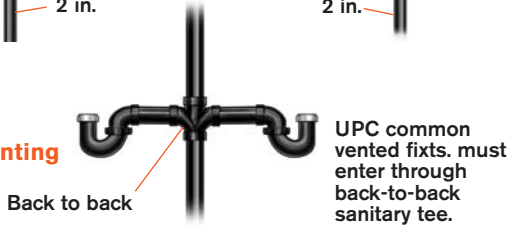
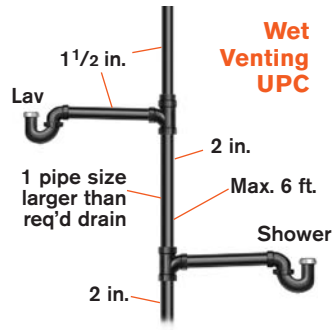

FIG. 36



Vertical Wet Venting

IRC

UPC

- Limited to trap arm of 1- & 2-unit fixt _____ [n/a] (908.1)
- All wet vented fixtures to be on same story _____ [3108.4] (908.1)
- 6ft max (vert only) developed length of wet vent **F36** _____ [n/a] (908.1)
- Size wet vent per DFUs of upper drains **T13** _____ [3108.3] {n/a}
- Wet vent 1 pipe size larger than the req'd waste-min 2in [n/a] (908.2)
- 4 fixts max on wet vent _____ [n/a] (908.1)

TABLE 13

MAX. DFU LOADS FOR WET VENTS & CWV
[T3108.3 & 3111.3] & {908.2 & 908.4.3}

Pipe Size (in.)	Wet Vents		CWV [IRC]	
	IRC	UPC	To Branch	To Bldg Drain
1 1/2	1	Ø	Ø	Ø
2	4	4	3	4
2 1/2	6	8 ^A	6	26
3	12	8 ^B	12	31
4	32	8 ^B	20	50

A. For horiz. wet vents, max. load is 4 DFUs on 2 1/2 in. pipe.
B. More than 8 possible for horiz. wet vents.

Horizontal Wet Venting

IRC UPC

- Horiz wet venting OK for any combination of fixt within 1 or 2 BA groups on same floor **F39** _____ [3108.1] {908.4.1}¹⁹
- Only fixts within BA groups allowed on wet vent. Other vented fixts may connect to the drain downstream of wet vent _____ [3108.1] {908.4.1}²⁰
- Dry vent connection to wet vent must be individual or common vent connected to lav, bidet, BT, or shower _____ [3108.2]²¹ {908.4.2}²²
- Side inlet 1/4 bends OK as a wet vent connection if not serving a WC _____ [3005.1.2] {n/a}
- Max trap arm length measured from trap weir to wet vent _____ [3108.5]²³ {908.4.1}
- Size wet vent per DFU & **T13** _____ [n/a] {910.1}



Code ✓ Check[®] HVAC Third Edition

BY DOUGLAS HANSEN AND REDWOOD KARDON

Illustrations and Layout by Paddy Morrissey

© 2007 by The Taunton Press, Inc. ISBN 1-XXXX-XXX-X

Code Check[®] is a registered trademark of The Taunton Press, Inc., registered in the U.S. Patent and Trademark Office.

For more information on the Building, Electrical, Mechanical, and Plumbing codes; valuable resources; and why Benjamin Franklin is featured in the Code Check series, visit: www.codecheck.com

Code Check HVAC (heating, ventilation and air conditioning) is a condensed field guide to the most commonly used residential mechanical codes. There are essentially two groups of mechanical codes that apply to construction of one- and two-family dwellings. One is the International Residential Code (IRC), and the other is the alliance of the Uniform codes and the NFPA codes. We have used several of these codes to emphasize their similarities and their common safety principles and to clarify distinctions between them.

Check with your building department to determine the codes and editions applicable in your area. If your area is using an older version of the codes, the list of code changes on pp. 180–181 will help in finding the rules that apply today in your area.

MODEL CODES & ORGANIZATIONS

ICC = International Code Council www.iccsafe.org

IAPMO = International Association of Plumbing & Mechanical Officials www.iapmo.org

NFPA = National Fire Protection Association www.nfpa.org

TABLE 1		CODES REFERENCED IN CODE CHECK HVAC
Organization	Code	
ICC	2006 IRC	International Residential Code
IAPMO	2006 UMC	Uniform Mechanical Code
IAPMO	2006 UPC	Uniform Plumbing Code
NFPA	2006 NFPA 54	National Fuel Gas Code
NFPA	2004 NFPA 58	Liquefied Petroleum Gas Code
NFPA	2006 NFPA 31	Standard for Installation of Oil-Burning Equipment
NFPA	2006 NFPA 211	Chimneys, Fireplaces & Solid Fuel-Burning Appliances
NFPA	2005 NFPA 70	National Electrical Code

The code changes referenced on pp. 180–181 compare the codes in this table to the 2003 IRC & the 2003 UMC.

FIG. 1

The HVAC System

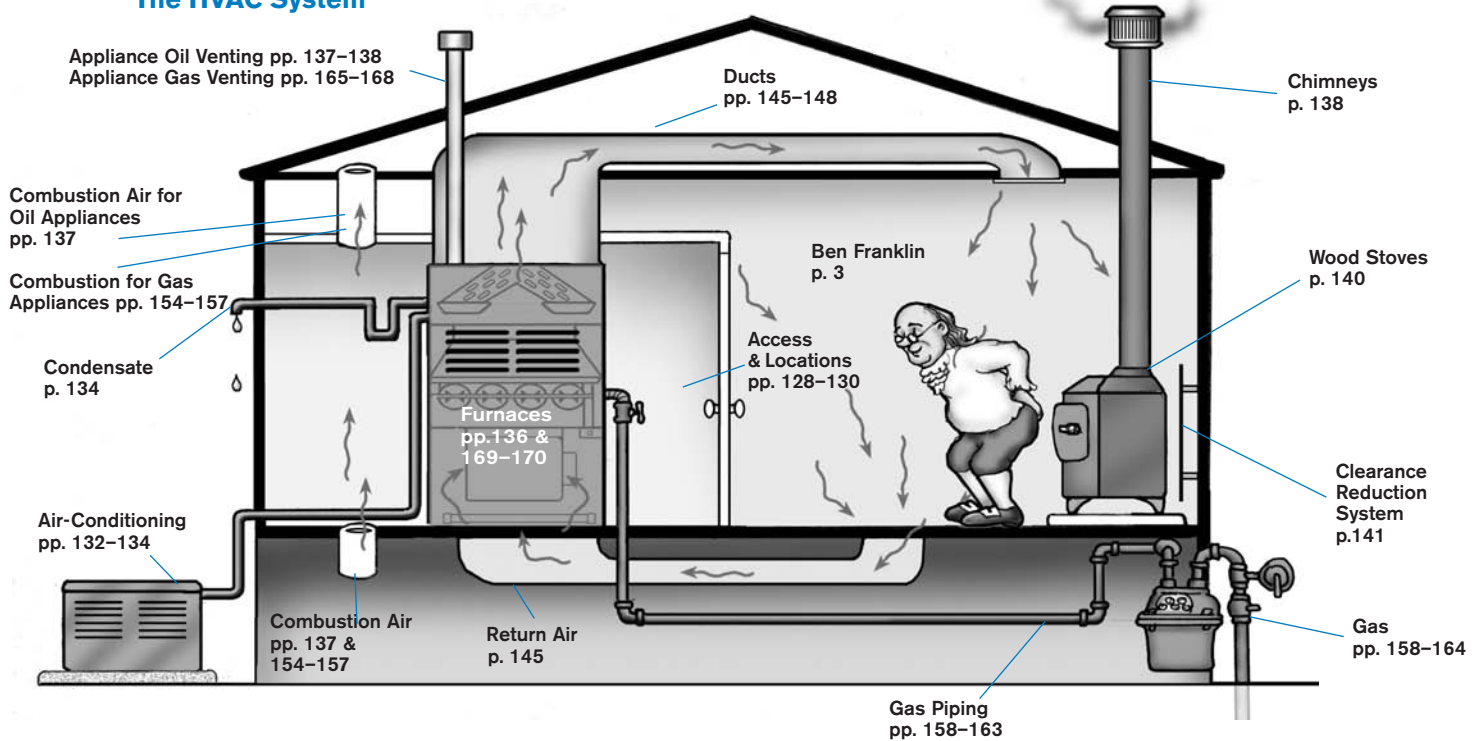

HEAT PUMPS & AIR-CONDITIONING

Cool air is heavier than warm air. Furnace blowers that also provide cooling must have 2-speed fans that overcome the resistance of the cooling coil and the weight of the cooled air. A retrofitted air conditioning coil should not be installed in an existing furnace unless it has the proper type of blower for the application.

Heat Pumps & Air-Conditioning

06 IRC 06 UMC

- Heat pump return air duct min 6sq.in per kBtu output **T2** _____ [1403.1] {manu}
- Outdoor unit on min 3in raised pad **F9** _____ [1308.3,1403.2]⁶ {1106.2}
- Furnace w/ cooling coil must have adequate pressure capacity [min 0.5in water column] or be L&L for cooling[1411.2] {904.8A&B}
- Cooling coil downstream from heat exchangers unless L&L for upstream (stainless-steel heat exchanger) _____ [1411.2] {904.8C}
- Central air-conditioner req's air filter **F7** _____ [1401.1] {312.1}
- Condenser not near clothes dryer vent _____ {manu} {manu}
- Refrigerant vapor (suction) lines insulated min R4 **F7** _ [1411.5] {manu}
- Nail-plate protection for refrigerant piping close to [$<1\frac{1}{2}$ in] framing edge _____ [2603.2.1] {1111.3}
- Tubing secured ≤ 6 ft of first 90° bend from compressor {manu} {1111.2}
- Tubing secured within 2ft of all other bends _____ {manu} {1111.2}
- Tubing supported at points ≤ 15 ft apart _____ {manu} {1111.2}

Electrical Requirements

06 IRC 05 NEC

- Disconnect in sight of condenser **F9** _____ [4001.5] {440.14}
- Disconnect cannot be mounted on access panels _____ [T4001.5] {440.14}
- Working clearance req'd in front of disconnect **F9** _____ [3305.1] {110.26}
- Clear space min 30in wide x 36in deep **F9** _____ [3305.2] {110.26A1}
- Thermostat wire not inside power conduit **F9** _____ [4204.1] {725.55A}
- Size conductors & overcurrent per nameplate _____ [3602.11] {440.4B}

FIG. 9

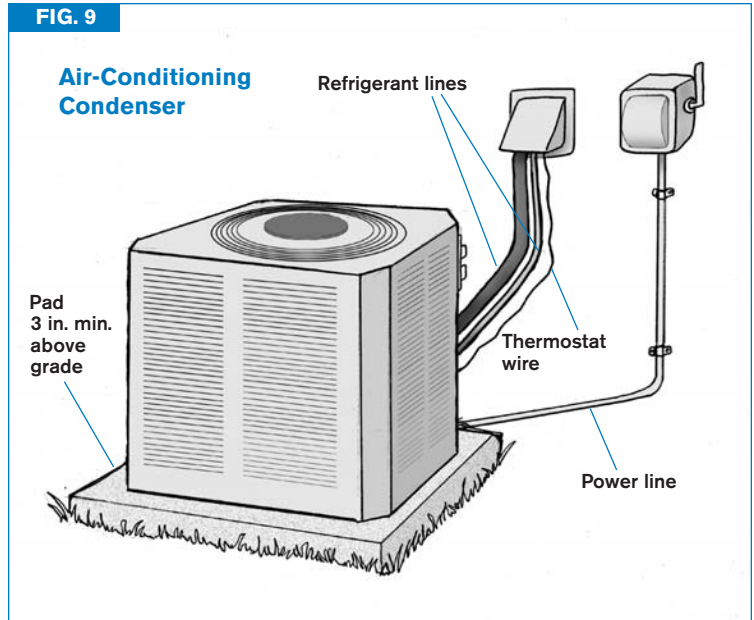

TABLE 2

HEAT PUMP RETURN DUCT MIN. SIZES [1403.1]

	24k	30k	36k	42k	48k	60k
Btu rating	24k	30k	36k	42k	48k	60k
Tons	2	2.5	3	3.5	4	5
Blower (sq. in.)	144	180	216	252	288	360
Round duct diameter	14 in.	16 in.	18 in.	18 in.	20 in.	22 in.

FIG. 13

Buried Oil Tanks

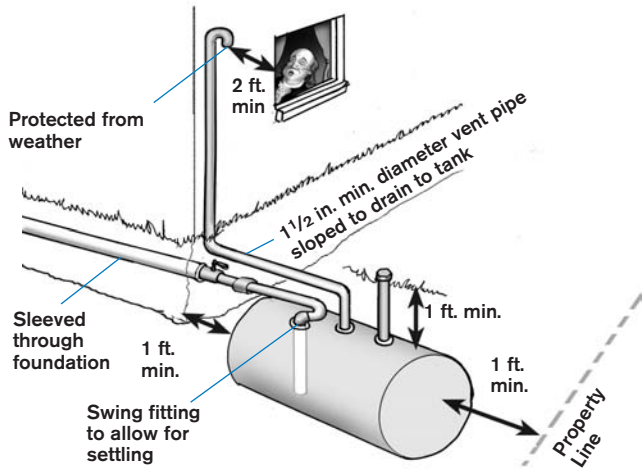

Fill & Vent Piping

06 IRC NFPA 31

- Fill pipes outside & min 2ft from building openings & equipped w/ tight metal cap [2203.3] {8.3.2}
- Vent pipe min 1 1/4in diameter **F13,14** [2203.4] {7.5.11}
- Vent 1in max penetration into tank **F13,14** [2203.4] {8.7.4}
- No cross-connections of vent to other piping [2203.4] {8.7.12}
- Weatherproof vent cap (gooseneck) **F13,14** [2203.5] {8.7.6}
- Vent must slope to drain to tank, no traps **F13,14** [2203.4] {8.7.1&2}
- Vent termination min 2ft from building openings & above snow **F13,14** [2203.5] {8.7.5}A

FIG. 14

Indoor Oil Tanks

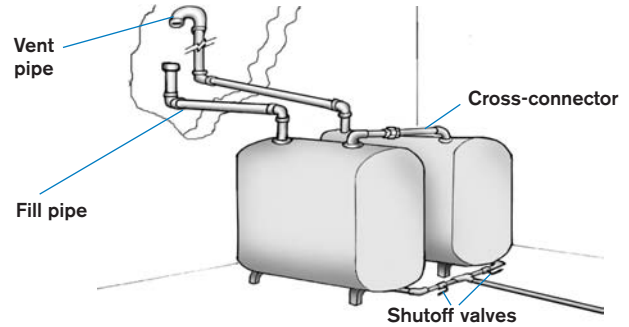

Oil Appliances, General

06 IRC NFPA 31

- Appliance & burners must be listed [1302.1] {13.2}
- Used appliances not OK to install in dwellings [n/a] {12.3}

Oil Piping

- Steel pipe or tubing, {brass pipe}, or type L Cu tubing (no aluminum) [2202.1, 2203,2] {8.2.2}
- No cast-iron fittings [2202.2] {8.2.8.5}
- Piping min 3/8in outside diameter [2203.2] {8.2.6}
- Listed flex metal hose OK to reduce vibration [2202.3] {8.2.5}
- Shutoff req'd between tank & burner [2204.2] {8.6.4}
- If shutoff on discharge of oil pump, PRV shall bypass or return surplus oil [2204.2] {8.8.8}
- Pumps must be L&L and installed AMI [2204.1] {8.8.6}
- Lines w/ heaters must have PRV & return line [2204.4] {8.8.9}

CLEARANCE-REDUCTION SYSTEMS

Clearance-reduction systems are used with solid-fuel, oil-burning, and gas-burning appliances. The information in **T3** is virtually identical in IRC chapter 13, chapter 24, and in NFPA 211. Clearance-reduction systems provide a practical means of installing appliances in spaces where they otherwise might not fit or would take too much space in a room.

General

06 IRC **06 UMC**

- Clearance reductions allowed per **T3**[1306.2, 1803.3.4, 2409.2] {12.6.2.1}
- Solid-fuel appliances not allowed to be reduced to <12in EXC _____ [1306.2.1] {12.6.2.1.2}
 - Appliances listed for <12in & installed AMI _____ [1306.2.1] {12.6.2.1.2}
- Unlisted appliance 36in sides & rear 48in top clear OR __ [n/a] {12.6.1}
 - Lesser amount OK w/ approved clearance-reduction system [n/a] {12.6.2.1}
- No spacers directly behind appliance or connector **F15,16** _____ [F1306.2] {12.6.2.1.3}
- Use **T3** when clearance w/ no protection is 36in _____ [1306.2] {12.6.2.1.1}
- 3 1/2in masonry w/o ventilated space max wall reduction 33% _____ [n/a] {12.6.2.1.1}
- 1/2in insulation board over unvented batts max wall reduction 50% _____ [n/a] {12.6.2.1.1}
- Other methods max wall reduction 66% _____ [n/a] {12.6.2.1.1}

Recommended Inspections of Existing Chimneys NFPA 211 14.3

- Level 1:** All readily accessible areas of chimney, structure, & flue (*annually, during routine cleaning & when replacing appliance w/ similar appliance*).
- Level 2:** Level 1 + video scan of flue. Verify clearances & suitability of flues (*upon resale of property; upon addition or removal of appliances, adding or replacing w/ dissimilar appliance, or after operating malfunction*).
- Level 3:** Level 1 & 2 + removal of components as necessary to gain access (*when Level 1 or Level 2 cannot identify conditions deemed critical to renewed or continued use; fire or damage investigations*).

FIG. 16

Clearance-Reduction System

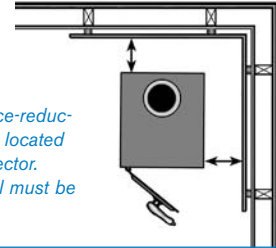

The spacers that hold out the clearance-reduction system from the wall must not be located directly behind the appliance or connector. The appliance's distance from the wall must be 12 in. min or in accordance with **T3**.

TABLE 3 ALLOWABLE REDUCED CLEARANCES^A [T1306.2]

Protection Method	Normal 18 in. Clearance Req'd.		Normal 36 in. Clearance Req'd.	
	Wall	Ceiling	Wall	Ceiling
3 1/2 in.-thick masonry w/o ventilated air space	12 in.	n/a	24 in.	n/a
1/2 in. insulation board over 1 in. glass fiber or mineral wool batts	9 in.	12 in.	18 in.	24 in.
0.024 sheet-metal over 1 in. glass fiber or mineral wool over wire & ventilated air space	6 in.	9 in.	12 in.	18 in.
3 1/2 in.-thick masonry w/ ventilated air space	6 in.	n/a	12 in.	n/a
0.024 sheet metal w/ ventilated air space	6 in.	9 in.	12 in.	18 in.
1/2 in.-thick insulation board w/ ventilated air space	6 in.	9 in.	12 in.	18 in.
1 in. glass fiber or mineral wool batts sandwiched between two sheets 0.024 sheet metal w/ ventilated air space	6 in.	9 in.	12 in.	18 in.

A. Also based on NFPA-211 T9.5.1.2 & T12.6.2.1.

TABLE 11	PROCEDURES FOR SIZING GAS PIPE [2413.4.1.2] {1317.1}
1. Determine Btu/cu .ft. from local gas provider	
2. Determine cu. ft./hr. demand for each appliance	
3. Sketch layout w/ piping lengths to each appliance F43	
4. Determine total cu. ft./hr. demand on each pipe section	
5. Determine length to most remote appliance	
6A. (Longest-length method) Use T12 row for that length for all appliances	
6B. (Branch-length method) Use same T12 row for all sections in series w/ most remote appliance.	
For other branches, use actual length of each branch.	
<i>The longest-length method is more conservative & compensates for pressure losses throughout the system. The branch-length method has less leeway, & consideration should be given to the lengths of pipe fittings. The IRC, UMC, & NFPA 54 accept both methods. The UMC allows the branch-length method only up to a total demand of 250 cu. ft./hr.</i>	

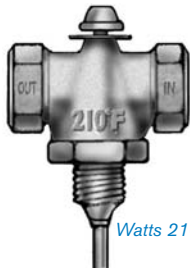

Watts 210 Gas Shutoff

Pressure relief valve

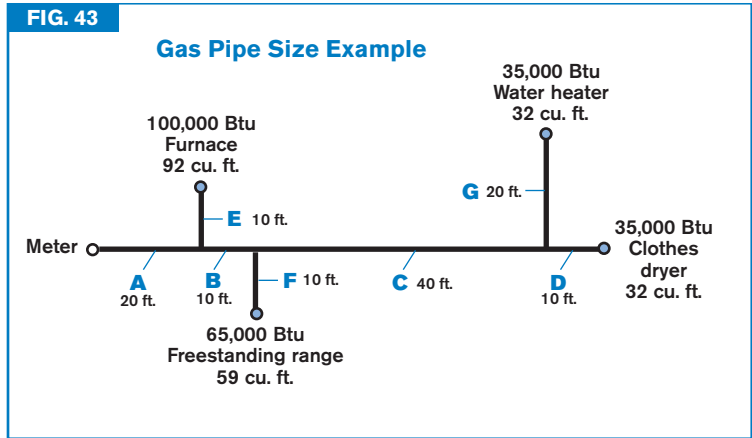

GAS PIPE SIZE EXAMPLE FILL-IN					
Pipe Section	Total cu. ft./hr.	Longest Length	Longest-Length Method	Actual Lengths	Branch-Length Method
A	214	90 ft.	1 1/4 in.	90 ft.	1 1/4 in.
B	123	90 ft.	1 in.	90 ft.	1 in.
C	64	90 ft.	3/4 in.	90 ft.	3/4 in.
D	32	90 ft.	1/2 in.	90 ft.	1/2 in.
E	91	90 ft.	3/4 in.	30 ft.	1/2 in.
F	59	90 ft.	3/4 in.	40 ft.	1/2 in.
G	32	90 ft.	1/2 in.	80 ft.	1/2 in.

HVAC CODE CHANGES IN 2006

1. 2003 UMC did not req protection against flood hazards.
2. 2003 IRC did not req work space to be level or 30in wide.
3. 2003 UMC did not address appliances in attics.
4. Allowance for 50ft distance is new in the 2006 IRC.
5. Allowance for unlimited distance is new in the 2006 IRC.
6. New requirement for equipment pad under all outdoor appliances.
7. The circuits were req'd to be sized to 125% of their load. By considering them to be continuous loads, the net effect on circuit size is the same.
8. 25amp circuits were not included in the 2003 IRC.
9. New option for an interlocked detector in lieu of a pan or secondary.
10. The requirement for an internal blockage detector is new.
11. The exemption for service receptacles at swamp coolers is new in 2006.
12. New requirement to remove exterior piping of abandoned tanks.
13. Bath fans must now be ducted to or directly connected to the outside of the building.
14. Dryer ducts must now terminate at least 3ft in any direction from other building openings .
15. Booster fans no longer allowed unless make & model of dryer are known & booster installed AMI.
16. ASHRAE calcs now OK for large-radius bends.
17. The rules for box support on paddle fans have been reformatted & moved to the section on boxes, w/ a reference in the appliances section of the electrical codes.
18. New UMC rule to create 18in access under ducts that restrict crawl access.
19. Mechanical fasteners for flex nonmetallic ducts must now be L&L.
20. Adhesives must now also meet the flame & smoke requirements.
21. In 2003, ducts req'd R-5 inside the building but outside the conditioned space. In 2006, ducts inside the building thermal envelope do not req insulation.
22. PEX & PP piping new in 2006 for IRC.
23. 2006 UPC includes new section on indirect-fired water heaters.
24. 2003 IRC req'd a temperature & pressure relief valve, not just a temperature limiting valve.
25. New rule for min 12in cover over buried propane lines.
26. The min size of screen mesh is new in the 2006 UMC.
27. Ducts of other materials must now have equivalent strength & rigidity as galvanized steel.
28. New rule that piping may not pass through one townhouse unit to another.
29. The word test has been replaced w/ check to clarify that another pressure test is not being req'd.
30. There are now separate ASTM standards for indoor & outdoor connectors.



Code ✓ Check[®] Electrical Fourth Edition

BY REDWOOD KARDON, DOUGLAS HANSEN, AND MICHAEL CASEY

Illustrations and Layout: Paddy Morrissey

© 2005 by The Taunton Press, Inc. ISBN 1-56158-783-9

Code Check[®] is a registered trademark of The Taunton Press, Inc., registered in the U.S. Patent and Trademark Office.

For more information on the Building, Electrical, Mechanical and Plumbing codes, valuable resources, and why Benjamin Franklin is featured in the Code Check series, visit: www.codecheck.com

HOW TO USE CODE CHECK ELECTRICAL

Code references are followed by two bracketed numbers, ex:

Code reference **T1,F1** _____ [123.4] {123.4}

Code numbers on left, in straight brackets, ex: [123.4], refer to 2002 NEC.

Code numbers on right, in braces, ex: {123.4}, refer to 2005 NEC.

T1 refers to Code Check Electrical table 1.

F1 refers to Code Check Electrical figure 1.

[manu] = Typically required by manufacturer's installation instructions.

Adoption and enforcement varies greatly, so check with your local jurisdiction.

An X after a code number refers to an exception in the code.

EXC = When placed at end of text line signals an exception in following line.

OR = When placed at end of text line signals an alternative in following line.

[n/a] = not addressed by the 2002 NEC.

{n/a} = not addressed by the 2005 NEC.

[Ø] = Prohibited by the 2002 NEC.

Codes ending in numbers separated by commas refer to multiple code sections,

ex: [210.8A2,5X2] = 2002 sections 210.8(A)(2) & 210.5(A)Exception2

A colored code citation followed by a superscript number indicates a change in the

code. Ex: [210.8B3]⁹ refers to a code change in the IRC, listed as #9 in the

Code Change Summary on pp 237–238.

EXAMPLES

Example of a code with figure number (from page 201)

Terminal bar for EGCs req'd to be provided **F26,27** [408.20] {408.40}

Panels require a terminal bar for the equipment grounding conductors. Found in 408.20 of the 2002 NEC and 408.40 of the 2005 NEC and is also shown in figures 26 and 27.

Example of a code change (from page 201)

OCPDs readily accessible {& max height 6ft 7in} _ [240.24A] {240.24A}²²

The explanation on p. 237 states that the 02 code only limited the height of breakers used as switches, and in 05 it applies to all breakers.

Example using "EXC" (from page 198)

Each bldg or structure requires GES EXC **F24** ___ [250.32A] {250.32A}

Bldg w/ only 1 branch ckt with EGC _____ [250.32AX] {250.32AX}

The basic rule requires the disconnecting means to be rated as service equipment with the exception of outbuildings that have only 1 circuit that can be controlled by a snap switch. This example is shown in figure 24.

Example using "OR" (from page 206)

Separate 20A ckt for bath recepts only OR _____ [210.11C3] {210.11C3}

Dedicated 20A ckt to each bathroom _____ [210.11C3X] {210.11C3X}

A circuit dedicated to the bathroom receptacles is required, or each bathroom can have its own dedicated circuit that supplies all the equipment in that bathroom.

ABBREVIATIONS

A = amperage, amps, ex. - a 15A breaker
AC = alternating current or air-conditioning
AC = armored cable, a.k.a. "BX"
addl = additional
AFCI = arc-fault circuit interrupter
AHJ = Authority Having Jurisdiction
AL = aluminum
appl(s) = appliance(s)
AWG = American wire gauge
bdg = building
BX* = trade name for AC cable
c&p = cord & plug
CATV = cable television
ckt(s) = circuit(s)
cu = cubic, ex: cu.in.–cubic inches
Cu = Copper
DB = direct burial
DC = direct current
DW = dishwasher
EGC = equipment grounding conductor
EMT = electrical metallic tubing
ENT = electrical nonmetallic tubing, aka smurf tubing
exc = except
ext = exterior
fixt = lighting fixture(s) (now called luminaire or luminaires)

FLA = full load amps (motor nameplate current rating)
FLC = full load current
FMC = flexible metal conduit, aka greenfield
ft = foot, feet
GEC = grounding electrode conductor
GES = grounding electrode system
GFCI = ground-fault circuit interrupter
horiz = horizontal
hr = hour, hours
HVAC = heating, ventilation & air conditioning
Hz = hertz (frequency, e.g., 60 cycles per second)
IMC = intermediate metal conduit
in = inch, inches
incl = includes, including
kcmil = 1,000 circular mill units (conductor size)
KO = knockouts **F9,10**
KVA = kilovolt amperes = 1,000 × volts × amps
L&A = lighting & appliance (panelboard)
L&L = listed & labeled, listing & labeling
lb = pound(s)
LCDI = leakage current detection & interruption
LFMC = liquidtight flexible metal conduit, a.k.a. sealtight

LFNMC = liquidtight flexible nonmetallic conduit
lum = luminaire(s) (lighting fixture)
manu = manufacturer
MC = metal clad cable
NM = nonmetallic sheathed cable (Romex®)
OCPD = overcurrent protection device (breaker or fuse)
PMI = per manufacturer's instructions
PV = photovoltaic
PVC = rigid nonmetallic conduit (RNMC)
recep = receptacle outlet
refrig = refrigerator
req = require, requiring
req's = requires
req'd = required

RMC = rigid metal conduit
RNMC = rigid nonmetallic conduit (PVC)
SE = service entrance cable
SFD = single-family dwelling
specs = specifications
sq = square
temp = temperature
UF = underground feeder cable
USE = underground service entrance cable
V = voltage, volts
VA = volt amps
vert = vertical
W = watts
w/ = with
w/o = without

MODEL CODES & ORGANIZATIONS

CSA = Canadian Standards Association; www.cssinfo.com/info/csa.html
IAEI = International Association of Electrical Inspectors; www.iaei.org
IRC = International Residential Code; www.iccsafe.org
NEC = National Electrical Code, published by the NFPA
NEMA = National Electrical Manufacturers Association; www.nema.org
NFPA = National Fire Protection Association; www.nfpa.org
NTRL = Nationally recognized testing laboratory, such as UL or CSA
UL = Underwriters Laboratory; www.ul.com

FIG. 1

The Electrical System

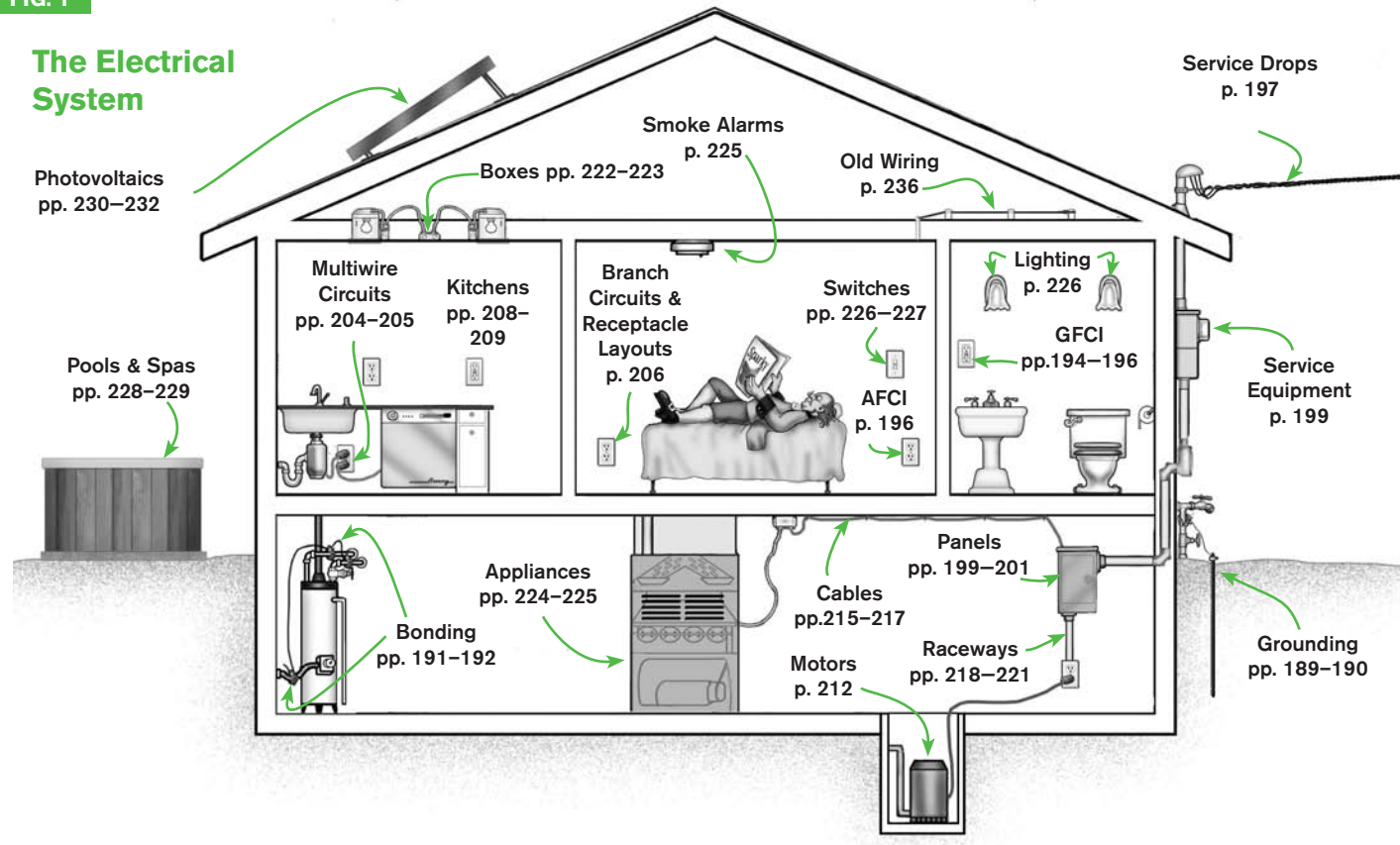
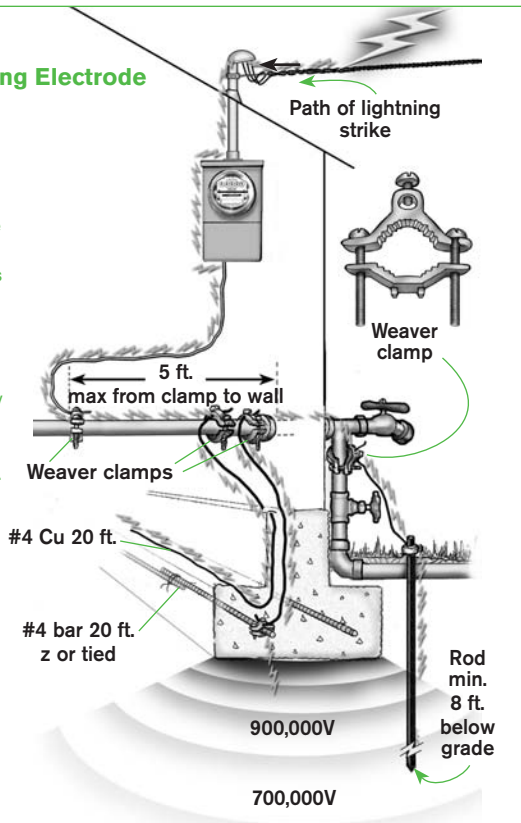

FIG. 6

Grounding Electrode System

The primary function of the grounding electrode system (GES) is to discharge the enormous voltages of a lightning strike away from the property & its inhabitants. Once the high-voltage electrical energy propagates through the soil, it is converted into heat & magnetic energy. The voltage drop is dramatic. During the microseconds of an electrical strike, voltage steps in the ground as short as 3 feet can produce as much as 100,000 volts of potential.



GROUNDING

Grounding Electrode Conductor

2002

2005

- GEC must connect to neutral at or before service_ [250.24A1] {250.24A1}
- Size per service conductor size **T1** _____ [250.66] {250.66}
- 6AWG Cu largest size GEC needed if ending at rod [250.66A] {250.66A}
- 4AWG Cu largest size GEC needed if ending at Ufer [250.66B] {250.66B}
- 8AWG must be protected by raceway or armor ____ [250.64B] {250.64B}
- 6AWG OK unprotected if not subject to damage & following bldg contour **F7** _____ [250.64B] {250.64B}
- Bond each end of metal raceway enclosing GEC **F8** [250.64E] {250.64E}
- No splices between service & GES _____ [250.64C] {250.64C}
- GEC can connect to any part of GES _____ [250.64F]⁴ {250.64F}
- Connections to metal water pipe that is part of GES must be within first 5ft of water pipe inside bldg **F6** _____ [250.52A1] {250.52A1}

GEC Connections

- Buried clamps must be L&L for direct burial **F6** _____ [250.70] {250.70}
- Cu water tubing clamps L&L for Cu tubing **F6** _____ [250.70] {250.70}
- Ufer clamps L&L for rebar & encasement **F6** _____ [250.70] {250.70}

Note: Rebar can be brought through the top of a foundation in a protected location, such as the garage, to provide an accessible location for the Ufer clamp.

- Strap-type clamps suitable only for phone systems ____ [250.70] {250.70}
- Max 1 conductor per clamp unless listed for more _____ [250.70] {250.70}
- Connections must be accessible EXC _____ [250.68A] {250.68A}
- Buried or encased connections **F6** _____ [250.70] {250.70}

FIG. 7

Bare GEC

"Acorn" clamp

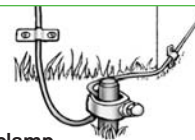

FIG. 8

GEC in Metal Raceway

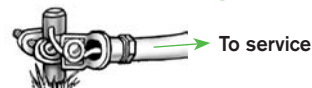
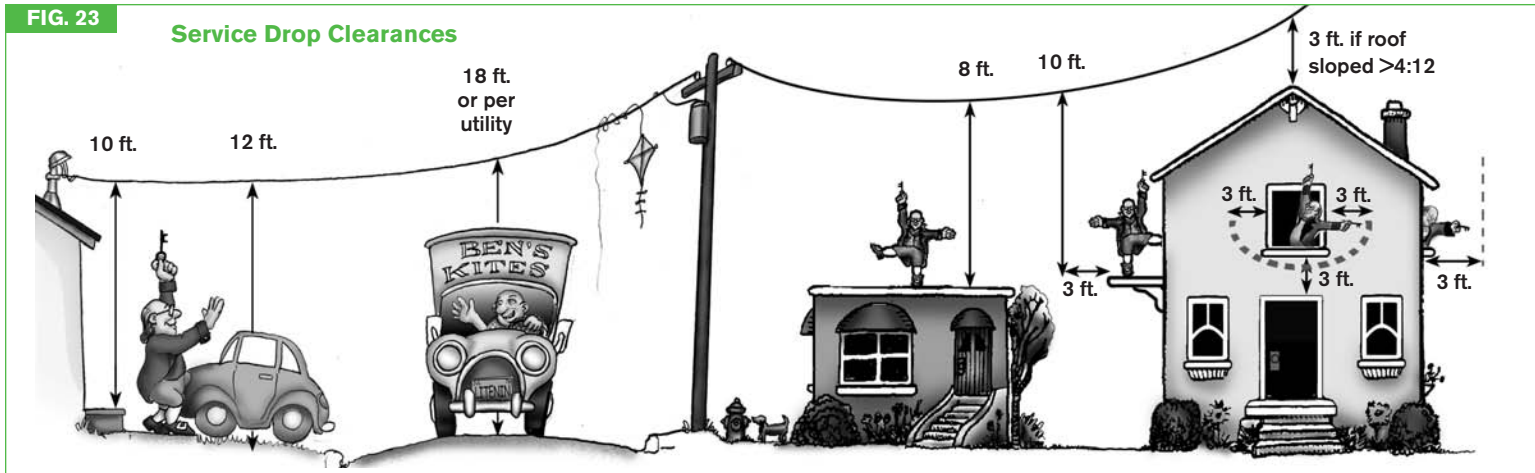

FIG. 23

Service Drop Clearances



SERVICE DROPS

The utility company does not necessarily follow the rules in the NEC. Check with your local jurisdiction and utility to find out what rules apply.

Clearances above Ground

- Area accessible only to pedestrians—10ft vert **F23** [230.24B1] {230.24B1}
- General above ground—12ft vert **F23** [230.24B2] {230.24B2}
- Above driveway—12ft **F23** [230.24B2] {230.24B2}
- Above roadway—18ft **F23** [230.24B4] {230.24B4}
- Any direction from pool water—22½ft [680.8A]¹⁶ {680.8A}¹⁷
- Trees may not support overhead conductors [230.10]¹⁸ {230.10}

2002 2005

Clearances above Roof

- <4-in-12 slope—min 8ft _____ F23 [230.24A] {230.24A}
- 4-in-12 slope or greater—min 3ft EXC _____ [230.24AX2] {230.24AX2}
- 18in OK over eave if mast ≤4ft horiz to edge **F26** [230.24AX3] {230.24AX3}

2002 2005

Clearances from Openings

- Below or to sides of openable window—3ft **F23** [230.9A] {230.9A}
- Above decks & balconies—10ft out to 3ft horiz **F23** [230.9B] {230.9B}

The NEC does not have a requirement for minimum clearance of open conductors above a window. Check to see if your local utility has a requirement.

TABLE 9

SIZING CONDUCTORS

Fuse or Breaker	Branch Circuits or Feeders Wire Size ^A		Service Conductors Wire Size ^B	
	Cu	AL	Cu	AL
15	14	12	n/a	n/a
20	12	10	n/a	n/a
25	10	10	n/a	n/a
30	10	8	n/a	n/a
35	8	6	n/a	n/a
40	8	6	n/a	n/a
45	6	4	n/a	n/a
50	6	4	n/a	n/a
60	6	3	n/a	n/a
70	4	2	n/a	n/a
80	3	1	n/a	n/a
90	2	1/0	n/a	n/a

Fuse or Breaker	Branch Circuits or Feeders Wire Size ^A		Service Conductors Wire Size ^B	
	Cu	AL	Cu	AL
100	2	1/0	4	2
110	1	1/0	3	1
125	1/0	1/0	2	1/0
150	1/0	2/0	1	2/0
175	2/0	3/0	1/0	3/0
200	3/0	4/0	2/0	4/0
225	4/0	250kcmil	3/0	250kcmil
250	4/0	300kcmil	4/0	300kcmil
300	300kcmil	400kcmil	250kcmil	350kcmil
350	400kcmil	600kcmil	350kcmil	500kcmil
400	500kcmil	700kcmil	400kcmil	600kcmil

A. Branch ckt. & feeder wire sizes are based on table 310.16 of the NEC. The 60°C column is used for sizes #1 or smaller, & the 75°C column is used for larger sizes.

B. Service conductor sizes are based on the wire types in NEC table 310.15(B)(6).

Motor circuit size example:

Motor nameplate = 3hp, 1Ø, FLA = 15amps, 230V, SF = 1.15

Overload protection = $15 \times 125\% = 18.75$

Full load current (FLC) = 17A (T8)

Conductor ampacity $\geq 17A \times 125\% = 21.25A$

Breaker size = $17A \times 250\% = 42.5A$

TD fuse size = $17A \times 175\% = 38.75A$

A 12AWG THW wire is OK (75°C column).

A 45A breaker is OK (next higher standard size).

A 40A TD fuse is OK (next higher standard size).